

AFKTOOLS

Tools for industry

Frezy pełnowęglkowe



AFK F06 UNI

FREZ UNIWERSALNY DO ZASTOSOWAŃ OGÓLNYCH

Optymalna geometria do wszechstronnych zastosowań oraz dobry stosunek jakości do ceny

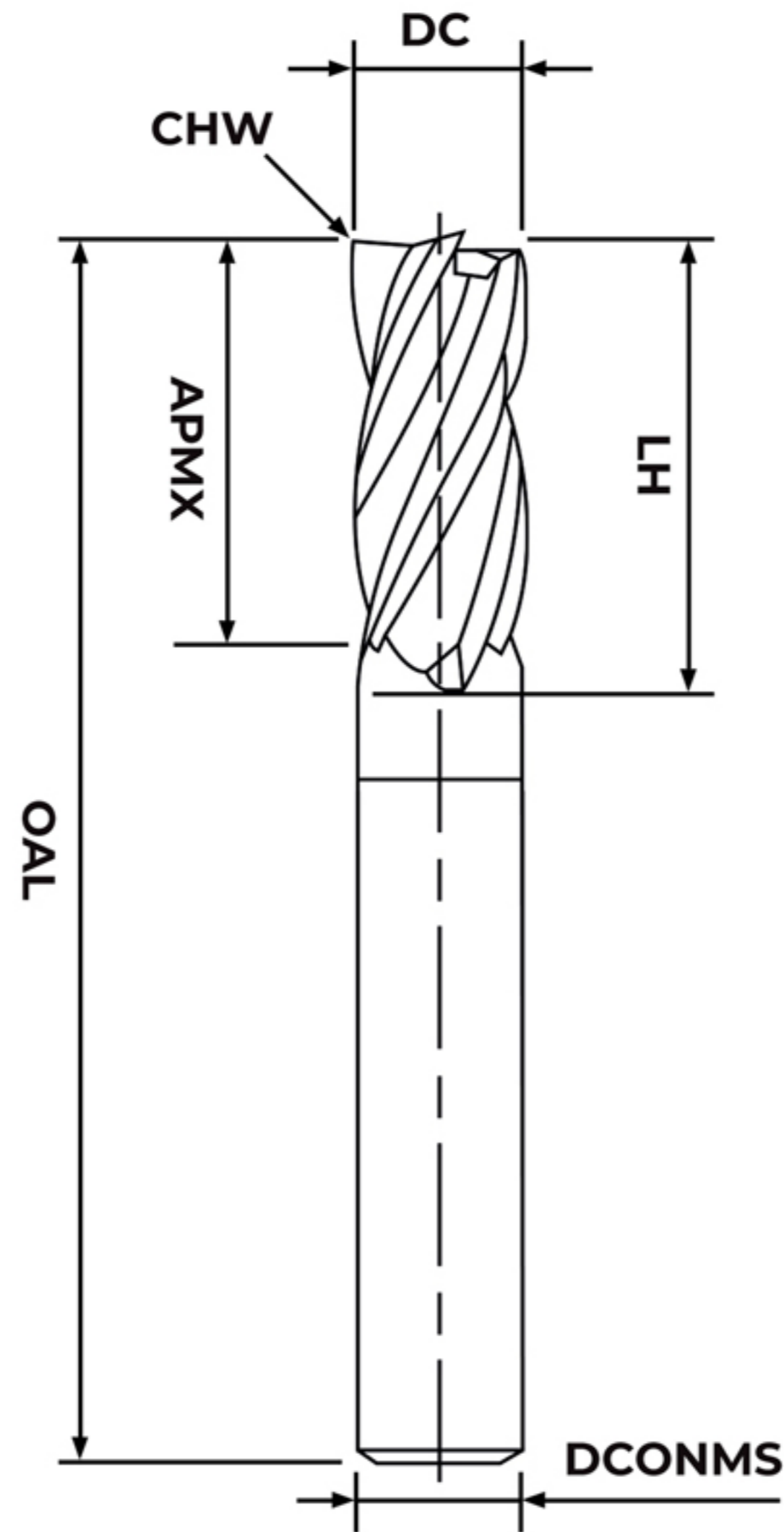

Materiał obrabiany

P	M	K	N	S	H
●	◐	●	◐	◐	◐

< 48 HRC

CHW $\lambda = 30^\circ$

TiAlN

ZEFP

DIN 6535 HA

DC f8	APMX	LH	OAL	DCONMS h6	CHW	ZEFP	Nr artykułu	EUR
mm	mm	mm	mm	mm	mm			
3	7	10	57	3	0,15	4	F06 030 HA UP	9,96
4	9	12	57	4	0,15	4	F06 040 HA UP	10,87
5	11	14	57	5	0,15	4	F06 050 HA UP	12,88
6	13	16	57	6	0,15	4	F06 060 HA UP	12,69
8	19	22	63	8	0,25	4	F06 080 HA UP	16,99
10	22	25	72	10	0,35	4	F06 100 HA UP	23,01
12	26	29	83	12	0,35	4	F06 120 HA UP	33,02
14	26	29	83	14	0,35	4	F06 140 HA UP	45,05
16	32	35	92	16	0,35	4	F06 160 HA UP	58,13
18	32	35	92	18	0,35	4	F06 180 HA UP	71,22
20	38	41	104	20	0,35	4	F06 200 HA UP	92,55

AFK F08 HPC

FREZ TRZPIENIOWY Z POGŁĘBIONYM ROWKIEM WIÓROWYM

Wysokowydajny frez o dużej trwałości do obróbki z wysokimi parametrami

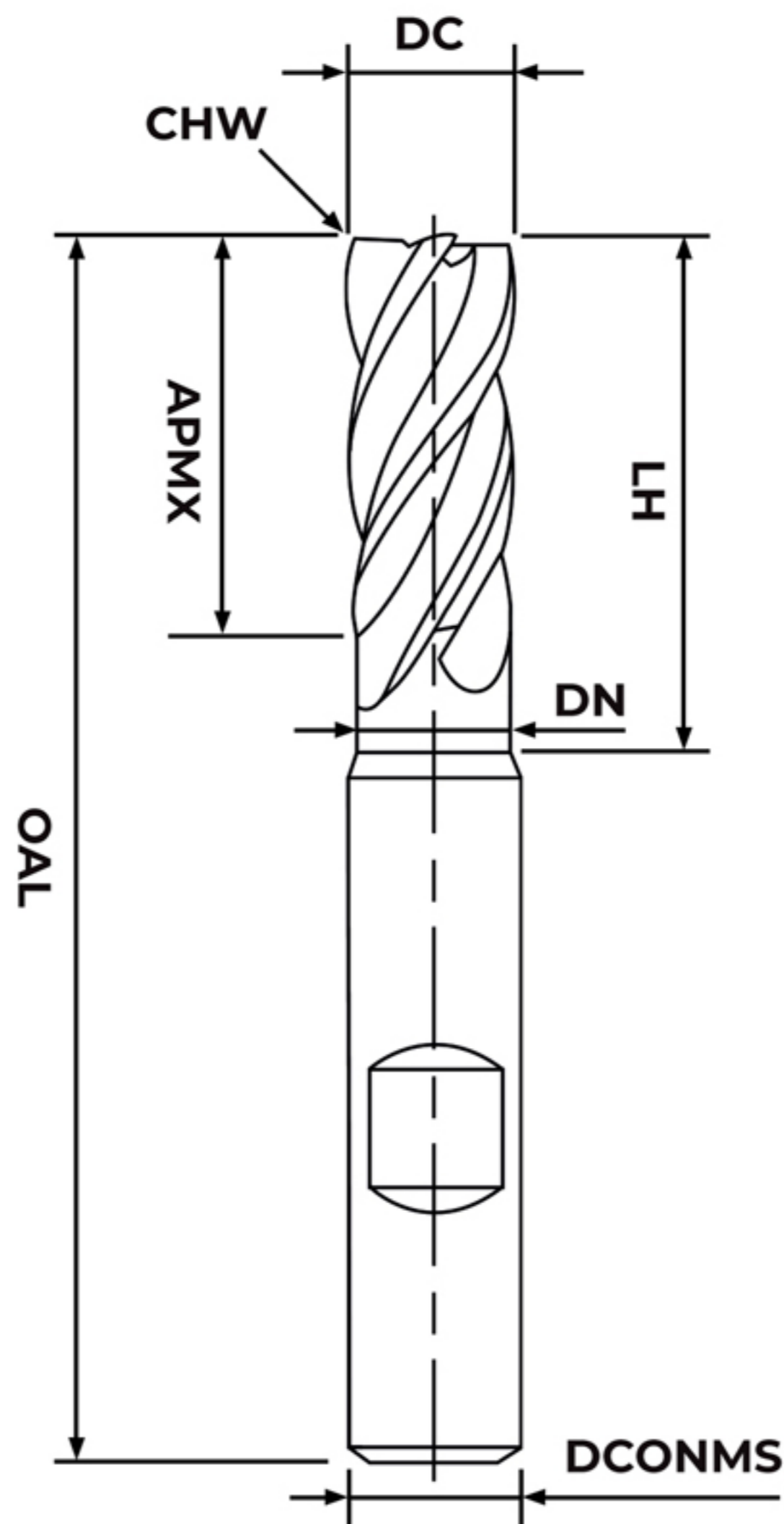

Materiał obrabiany

P	M	K	N	S	H
●	◐	●	◐	◐	◐

< 48 HRC

CHW $\lambda = 35^\circ / 38^\circ$

AITiSiN

ZEFP

DIN 6535 HB

DC f8	APMX	DN	LH	OAL	DCONMS h6	CHW	ZEFP	Nr artykułu	EUR
mm	mm	mm	mm	mm	mm	mm			

3	7	2,9	11	57	6	0,15	4	F08 030 HB TH	19,75
4	9	3,8	13	57	6	0,15	4	F08 040 HB TH	19,75
5	11	4,8	15	57	6	0,15	4	F08 050 HB TH	19,75
6	13	5,8	21	57	6	0,15	4	F08 060 HB TH	18,56
8	19	7,7	27	63	8	0,25	4	F08 080 HB TH	24,84
10	22	9,5	32	72	10	0,35	4	F08 100 HB TH	31,47
12	26	11,5	38	83	12	0,35	4	F08 120 HB TH	43,73
14	26	13,5	38	83	14	0,35	4	F08 140 HB TH	54,51
16	36	15,5	44	92	16	0,35	4	F08 160 HB TH	68,09
18	36	17,5	44	92	18	0,35	4	F08 180 HB TH	84,04
20	38	19,5	54	104	20	0,35	4	F08 200 HB TH	113,22



AFKTOOLS

ul. Młyńska 2
46-080 Chróścice

NIP: 7542692328

+48 693 010 282
info@afk-tools.com

www.afk-tools.com

